

ANALYSIS FOR THE EFFECT OF INVERTER RIPPLE CURRENT ON FUEL CELL OPERATING CONDITION



Randall S. Gemmen, Ph.D.
NETL/DOE
Morgantown, WV

**Presented at the 2001 International Mechanical
Engineering Congress and Exposition
New York, NY
11-16 November 2001**



Outline

- **Technical Issues for Fuel Cells**
- **NETL Models Used for Investigating Ripple Effects**
- **Results**
- **Conclusions**



Fuel Cell / Inverter Coupling



- Fuel cells require 'inversion' to AC power to be used by most of today's loads.
- FC source voltages can have any value, but residential/commercial/industrial loads require regulated 120 VAC @ 60 Hz within the US, and other specifications abroad.

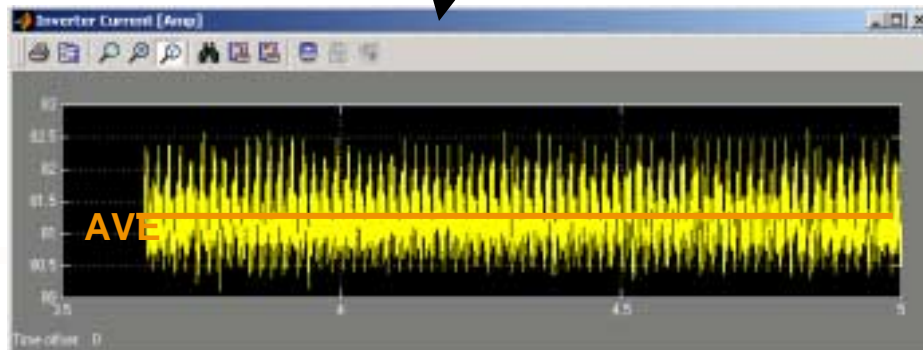
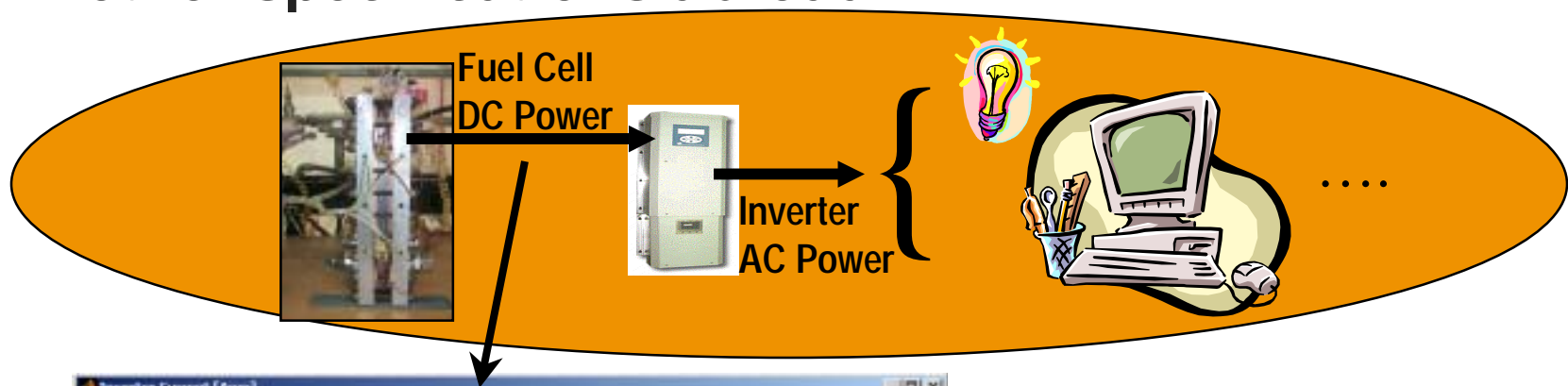

- Fuel cells prefer pure DC loads...



Ripple Current

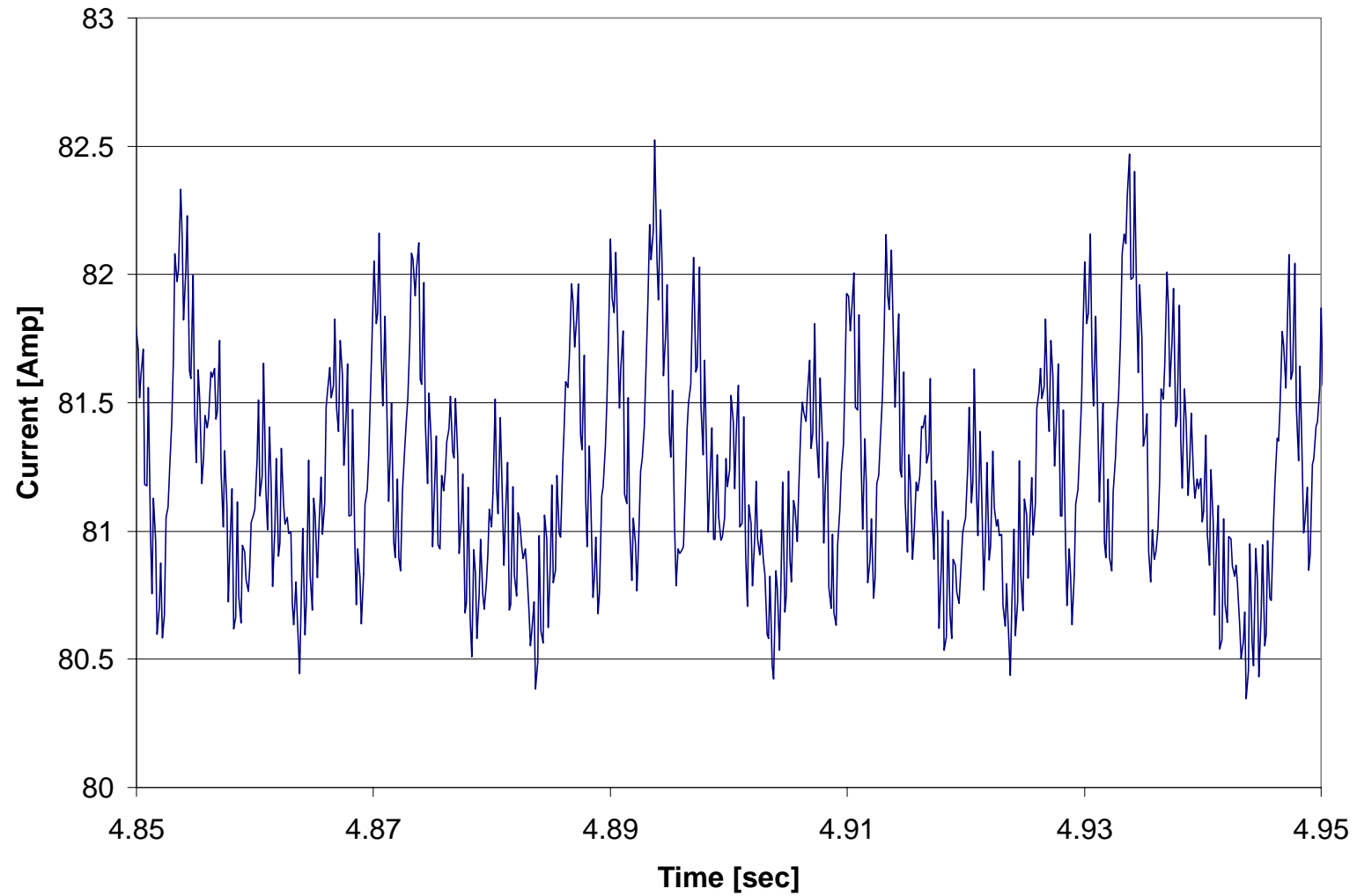

Hydrogen Utilization

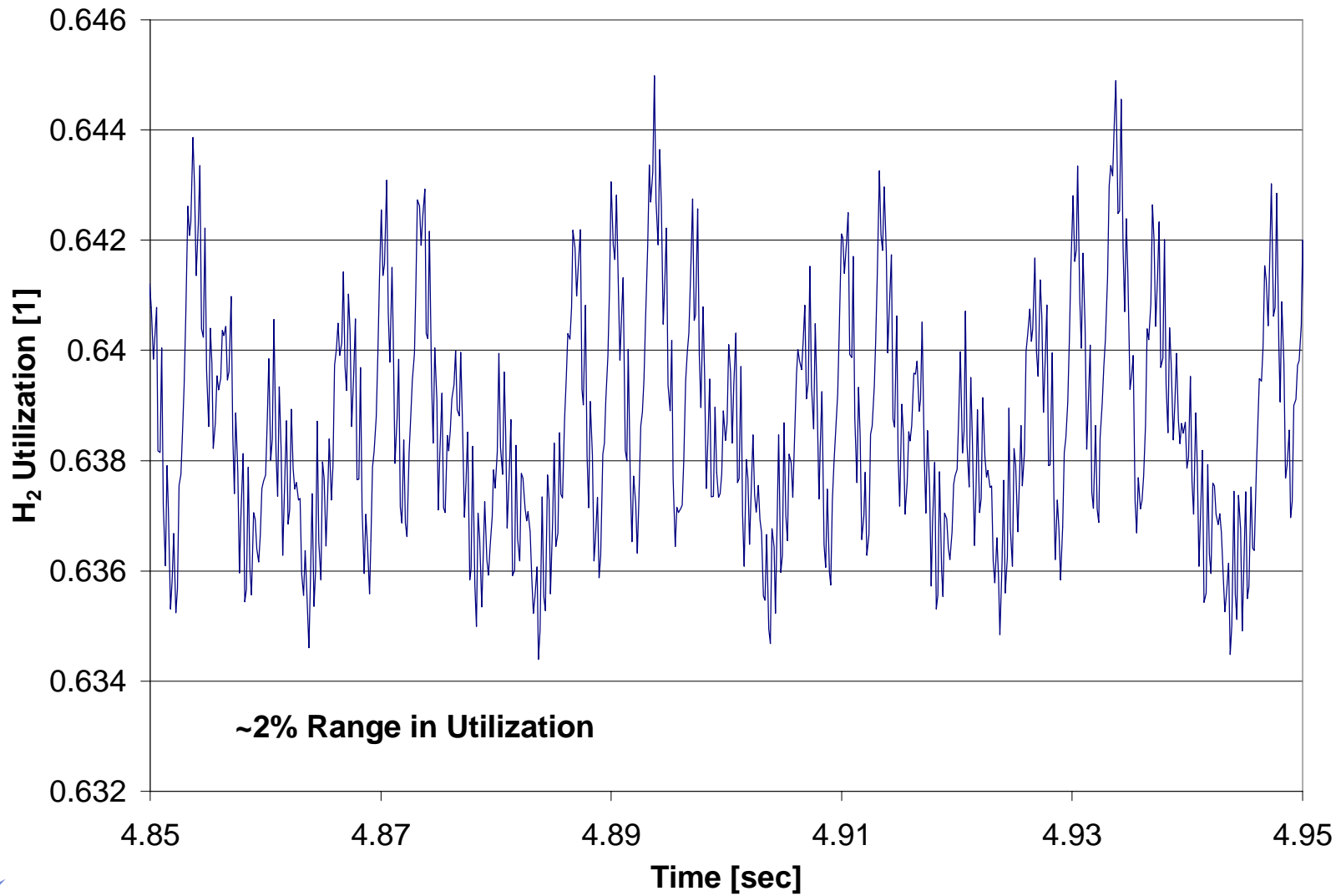

Technical Issues for Fuel Cells

- **Inverter loads are dynamic.**
- **Unmitigated, inverter ripple can momentarily impose high-consumption of reactant gas.**
- **Certain mitigation techniques can negatively impact fuel efficiency.**
- **Understanding is needed:**
 - What is the impact (degradation, etc.) of an inverter load?
 - What is the cutoff frequency where ripple no longer significantly impacts reactant concentrations?
 - Most test data is taken under steady (DC) loads--how will ripple loadings compare?



Overview of NETL Dynamic Models

- **Simulink (0-Dim) Models**
 - investigate systems issues
- **One-Dimensional Electrode Models**
 - study the physics of porous diffusion
- **Other Models at NETL:**
 - One-Dimensional Cell Models
 - predict fuel cell performance in systems evaluations
 - CFD Based Electrochemical Models
 - investigate detailed physical conditions within the fuel cell
 - based on presently available standard commercial software



Approach to Ripple Analysis

- Apply Simulink Model for bulk transient analysis of fuel cell + inverter problem.

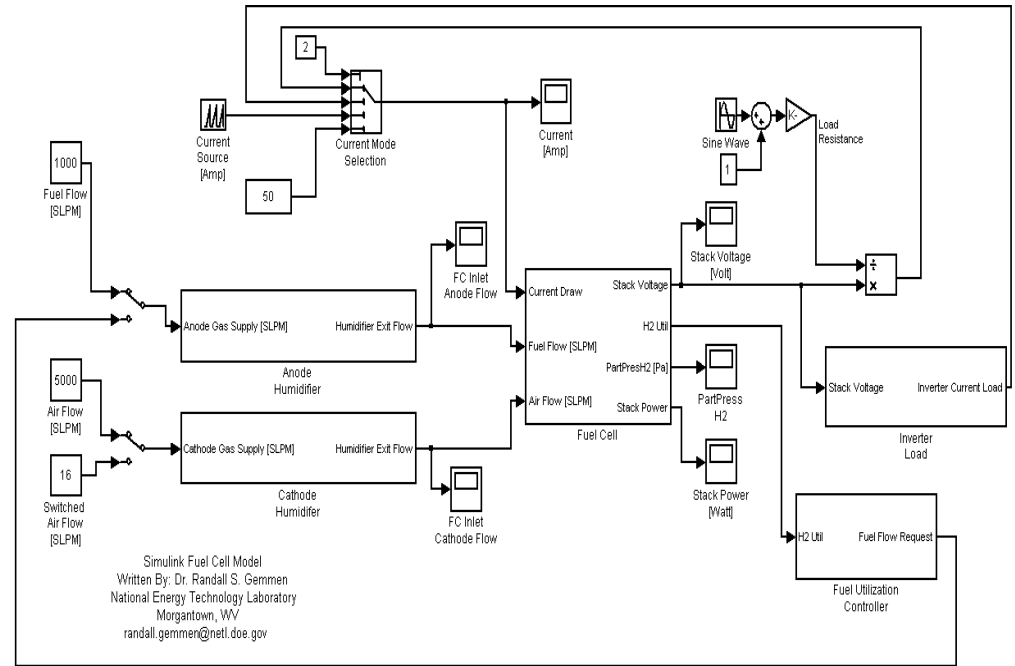

- Apply One-Dimensional Electrode Model for detailed transient analysis of ripple effects on electrode/membrane interfacial conditions.

$$\varepsilon \frac{dY_j}{dt} + u \nabla Y_j = D' \nabla^2 Y_j \quad D' = D \frac{\varepsilon}{\tau}$$



Simulink Model

- Zero-Dim. anode/cathode fuel cell model.
- Uniform & constant temperature: T=60 deg. C.
- Uniform & constant pressure: P=101000 Pa.

$$P_{\text{anode}} = P_{\text{H}_2} + P_{\text{H}_2\text{O}} \quad P_{\text{cathode}} = P_{\text{O}_2} + P_{\text{H}_2\text{O}} + P_{\text{N}_2}$$

- **Stack voltage:**

$$V_{\text{stack}} = N [E^{\circ} + RT/nF \ln(P_{\text{H}_2} P_{\text{O}_2}^{1/2} / P_{\text{H}_2\text{O}}) - Z \cdot I - \eta_e - \eta_D]$$

where, N = number of cells, η_e = electrochemical overpotential,
 η_D = diffusion overpotential, Z = cell impedance.

- **Cell impedance model accounts for cell electrical capacitance.**
- **Saturated inlet gas.**
- **Ignores condensation in channels.**



Ripple Model

- For both models, assume steady DC current component and a square wave ripple component imposed at the electrode/membrane interface:

$$I(t) = A \cdot S [1 + x \cdot \text{sq}(\omega \cdot t)]$$

where,

A = current amplitude factor [amp/m²]

S = active area [m²]

x = ripple factor [1]

sq($\omega \cdot t$) = square wave of unity amplitude and frequency ω .



Simulink Model Results

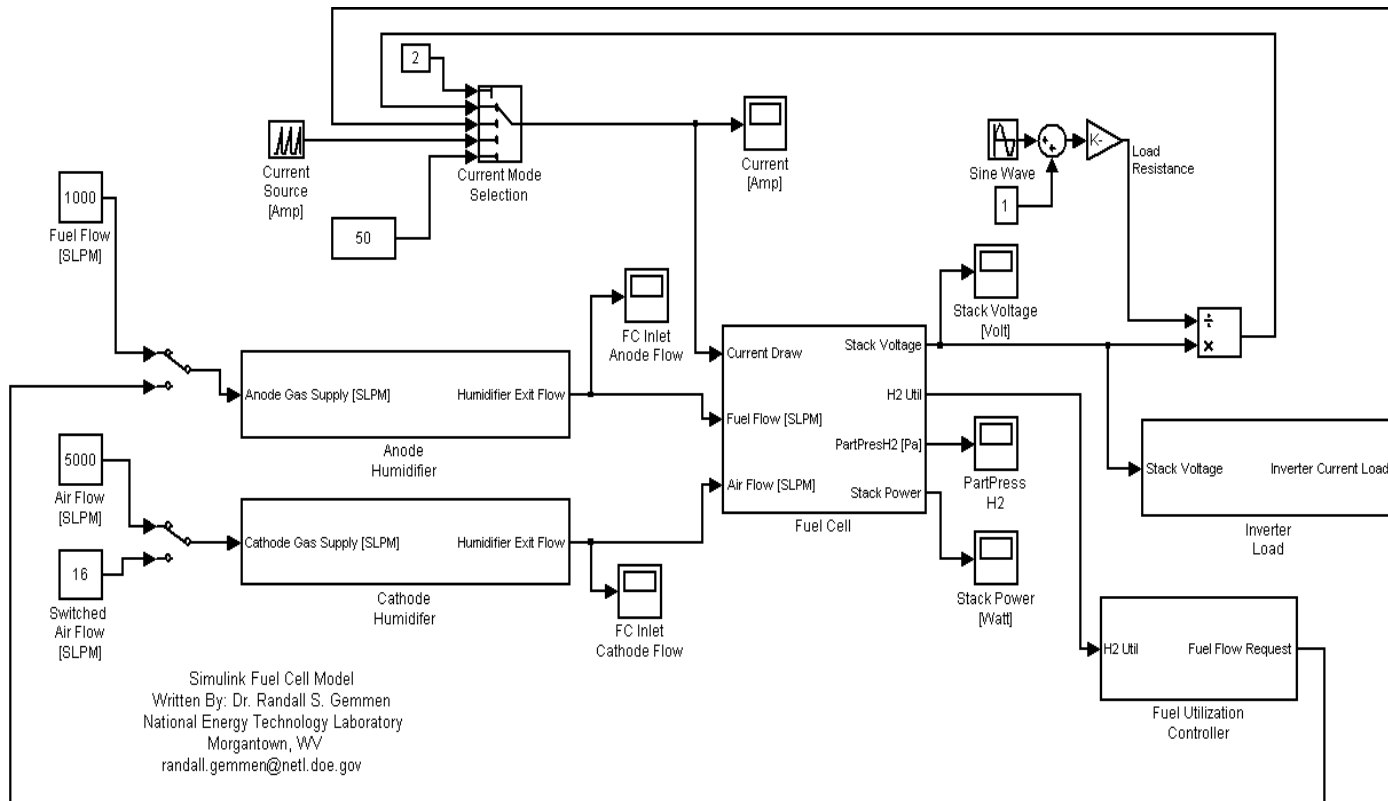

Simulink Predictions (Steady State)

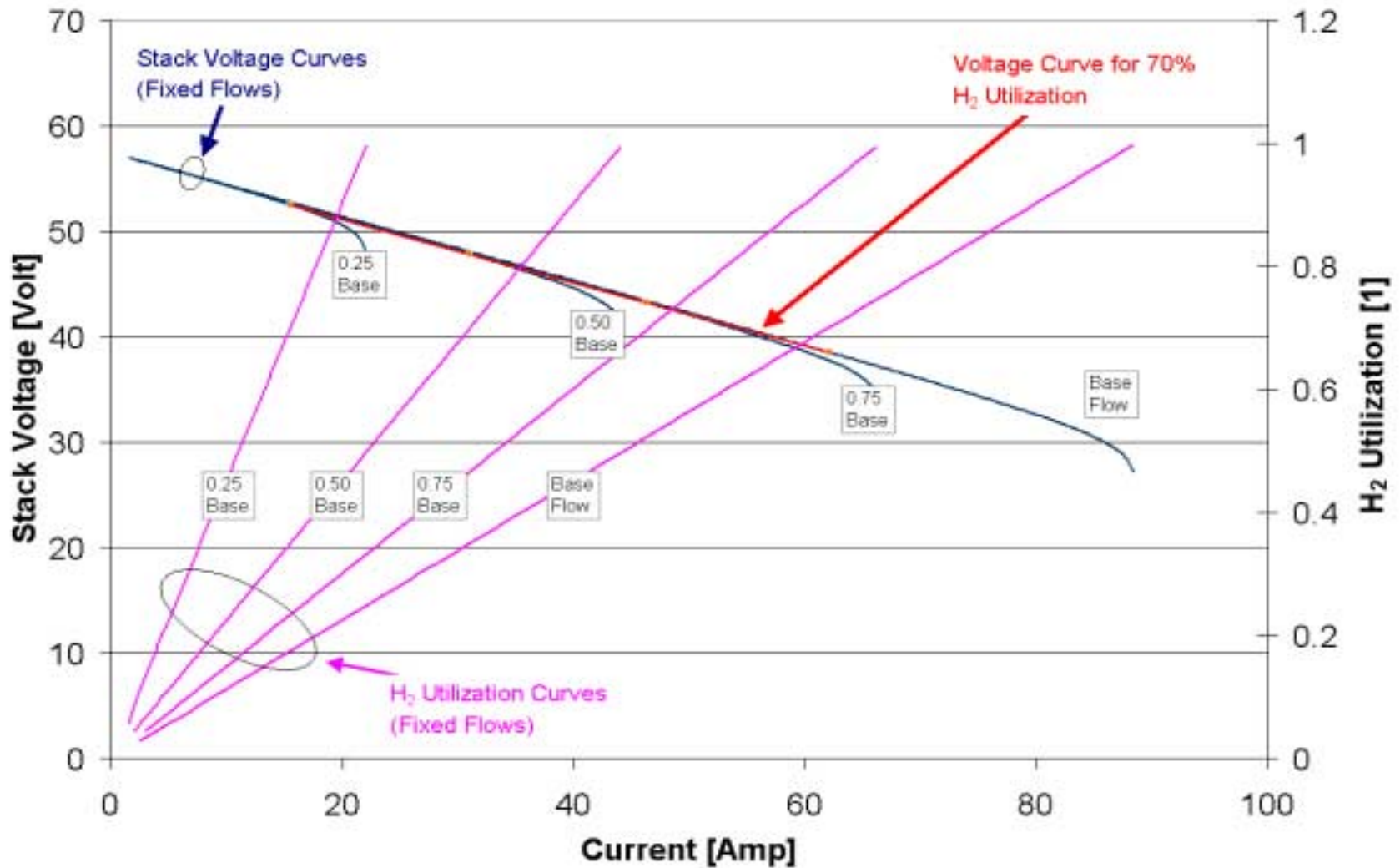

Impact of Inverter Dynamic Load

Bulk Behavior Predicted by Simulink

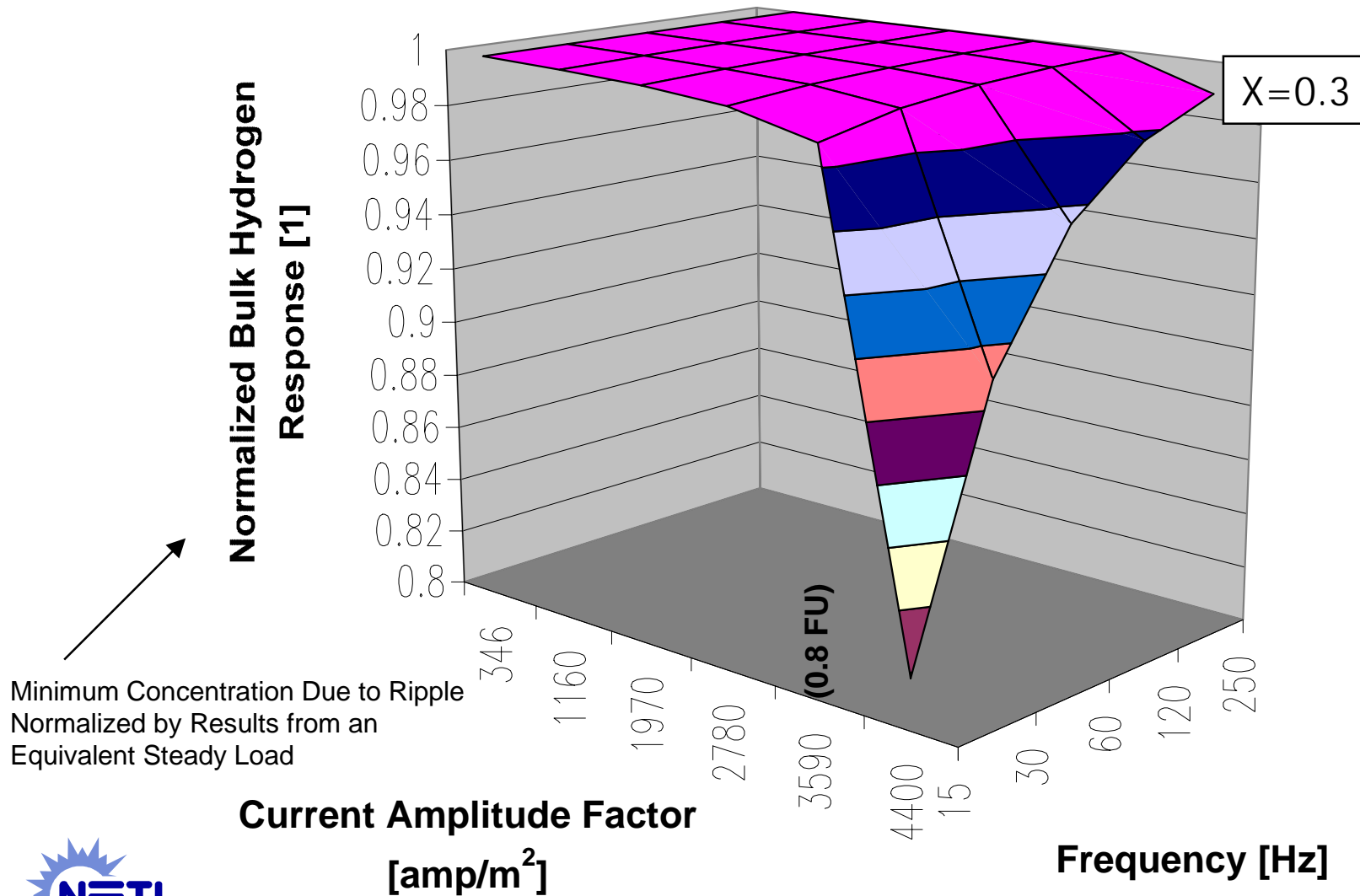

Electrode Model Results

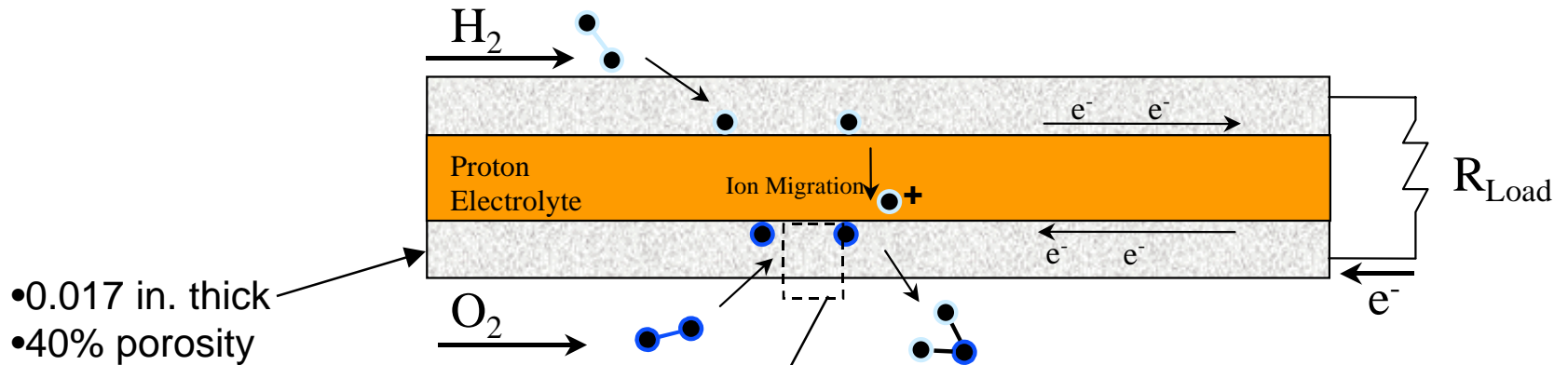

$$\varepsilon \frac{dY_j}{dt} + u \nabla Y_j = D' \nabla^2 Y_j$$

$$D' = D \frac{\varepsilon}{\tau}$$

$$u = N / \rho \varepsilon^{2/3}$$

Impact of Inverter Dynamic Load

Cathode Electrode Model O₂ Response (60 Hz)

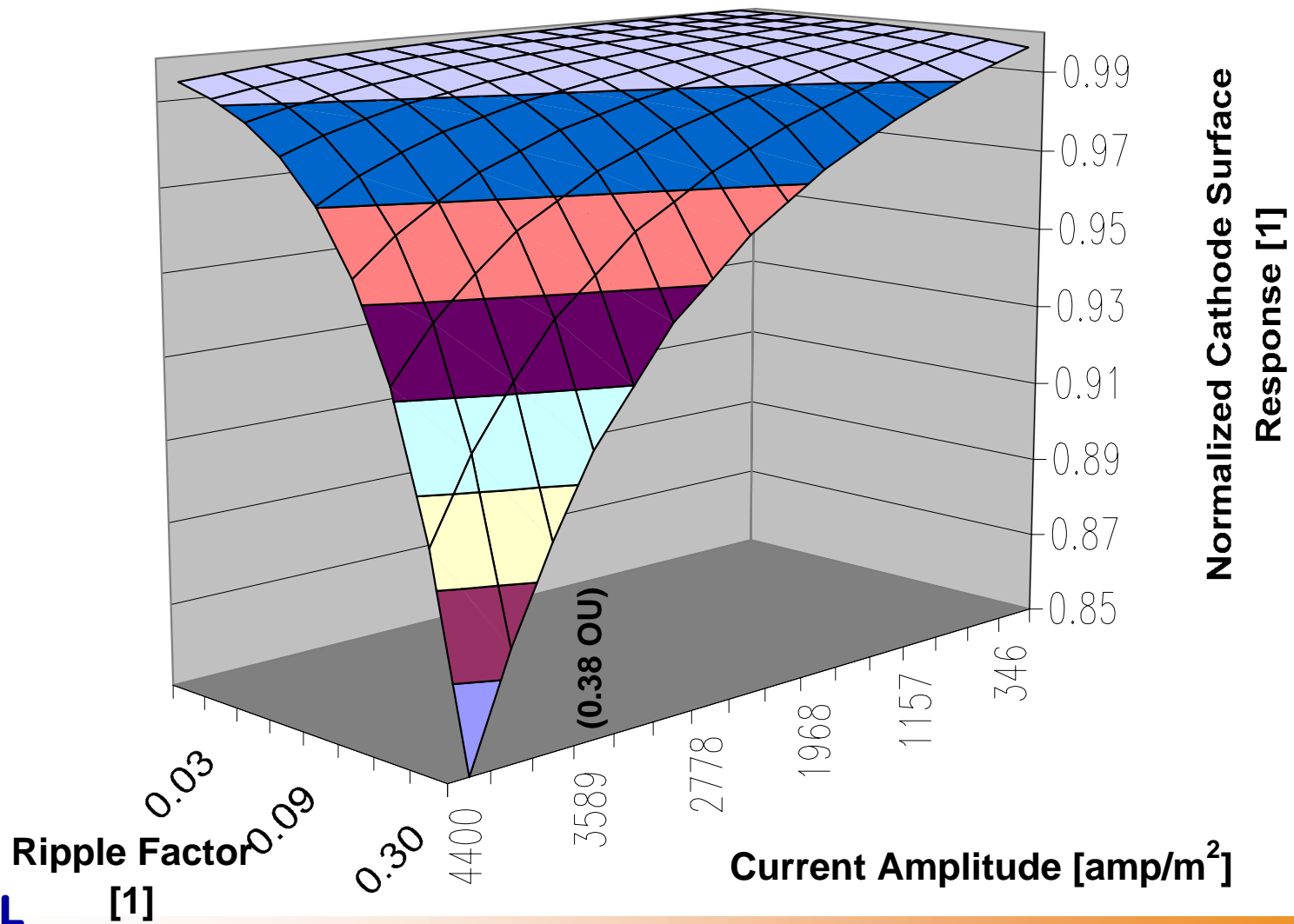

Impact of Inverter Dynamic Load

Cathode Electrode Model O₂ Response (120 Hz)

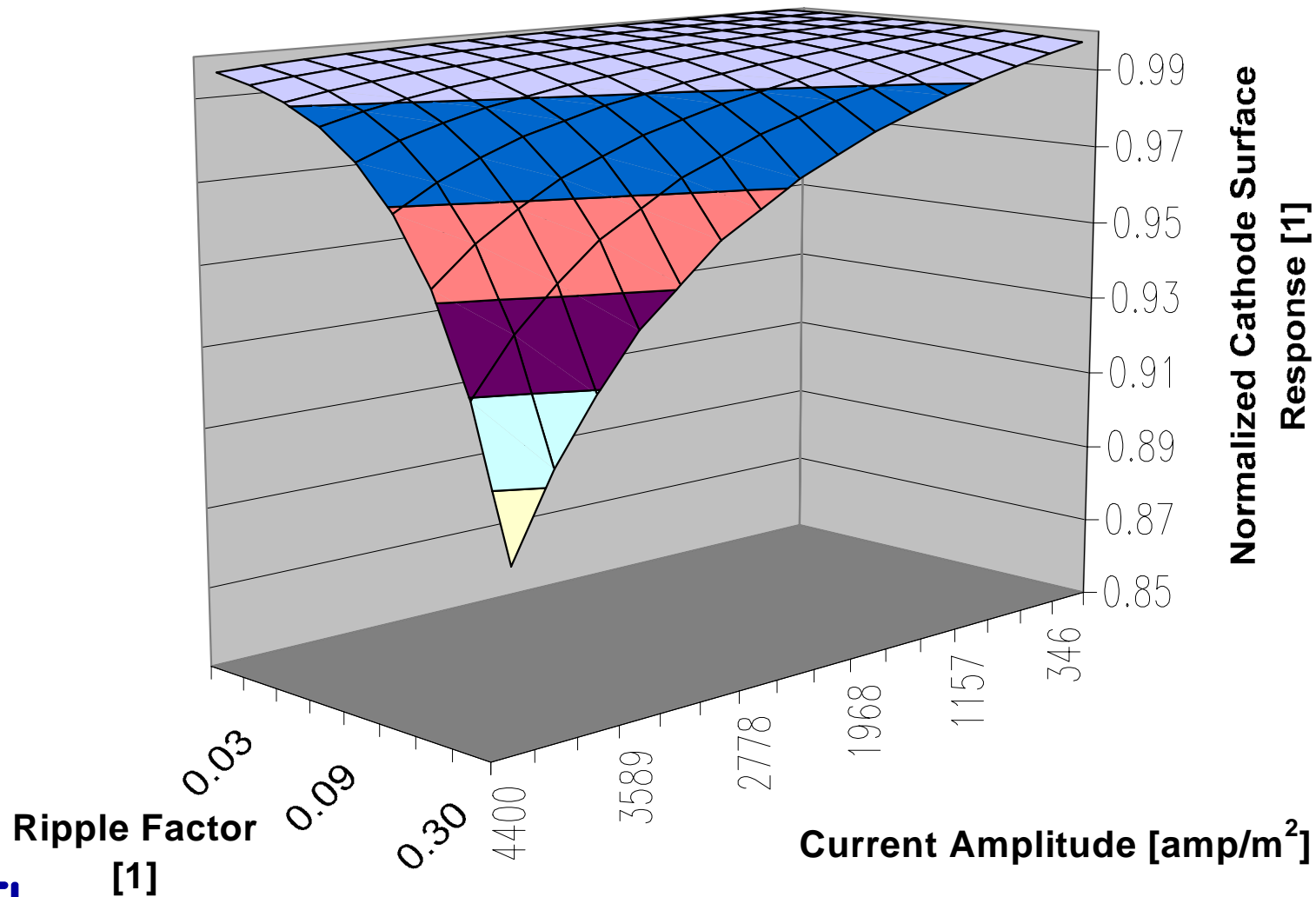

Impact of Inverter Dynamic Load

Cathode Electrode Model O₂ Response (1250 Hz)

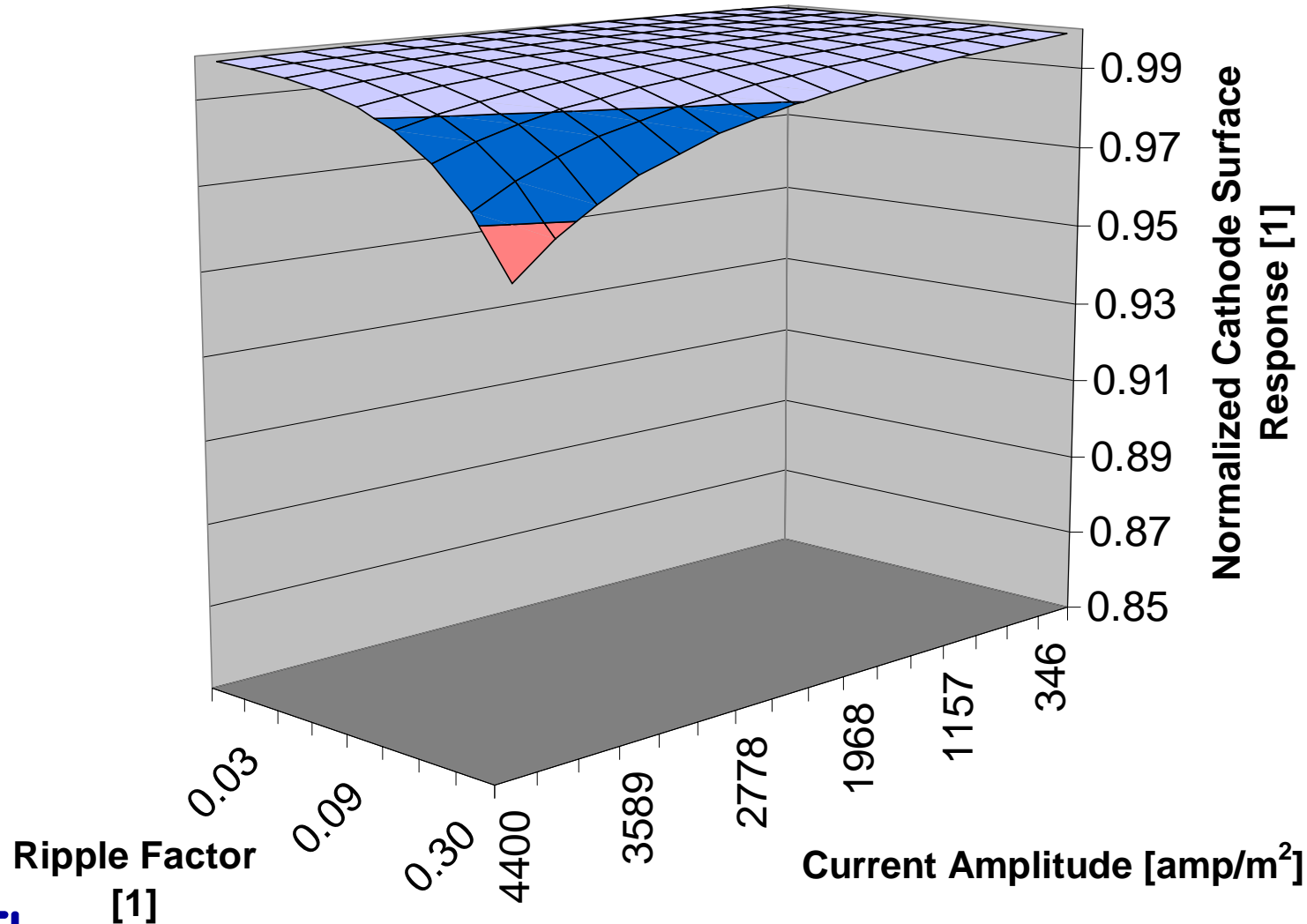

Frequency Response

Cathode Electrode Model O₂ Response (x=0.3; 4400 amp/m²)

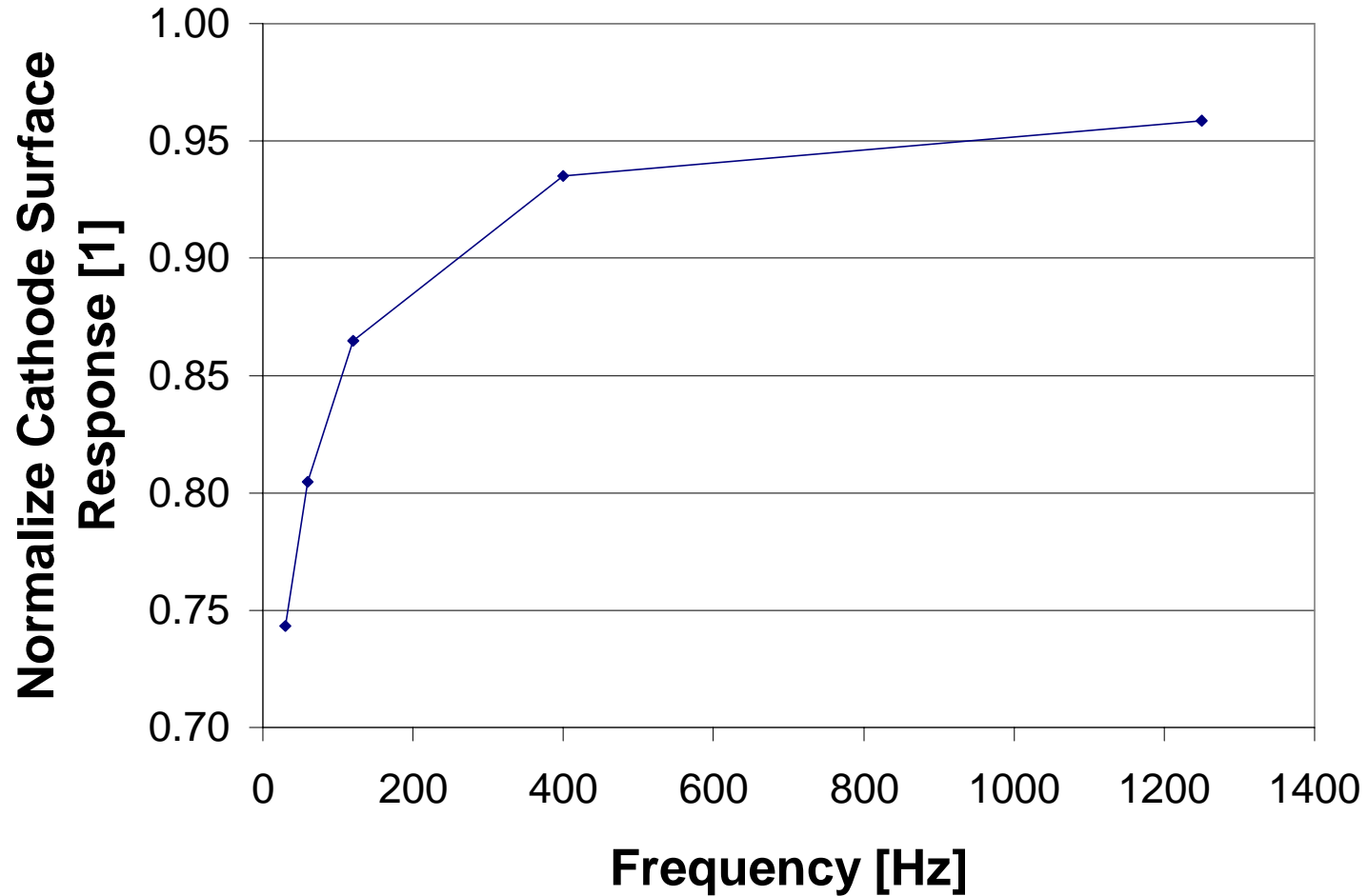

Conclusion

- **Unmitigated, inverter loads can significantly modify the conditions within and around the fuel cell electrodes as compared to *equivalent* steady loads.**
- **Cathode side is focus of concern. Anode side not impacted until extremely high utilization.**
- **To ensure minor impact to the fuel cell conditions, inverter ripple factors should be controlled to less than 4%.**
- **Ripple frequencies above 400 Hz have minor effects.**

