

Novel Mechatronic Compressor/Pump for Fuel Cell Systems

Dr. Longya Xu

Dept. of EE, The Ohio State University

Significance

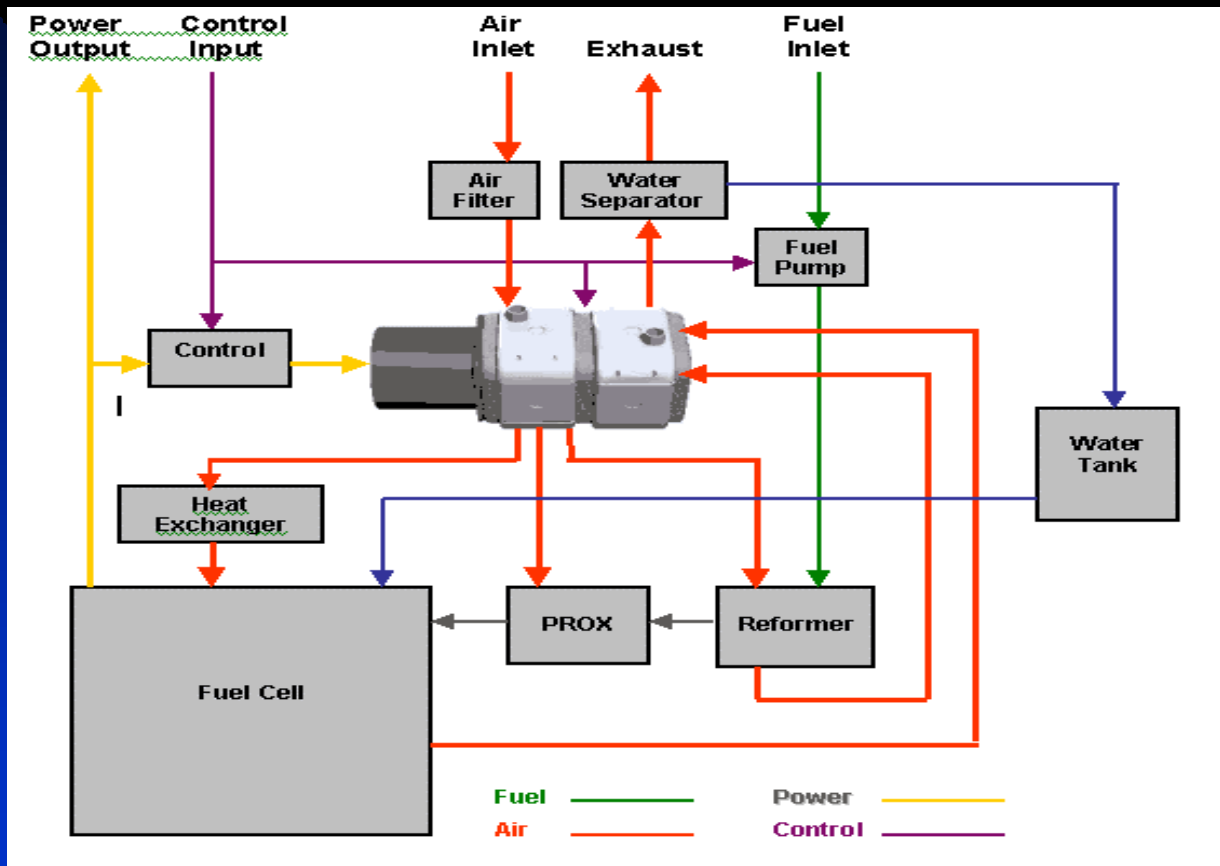

Compressor/Pump in a Fuel Cell System

- Regarded as the fuel cell system's heart,
- Ones currently used are bulky, consuming more than 20-30% energy, costs much - engenders the largest single system losses

The novel compressor/pump aimed at:

- much reduced size and enhanced reliability;
- built-in air bearing, free of friction and lubricant;
- optimized geometry of blades for high efficiency
- independent control of flow rate and pressure.

Concept of Integrated Compressor/Pump

Compressor House

Stator and Control Electronics

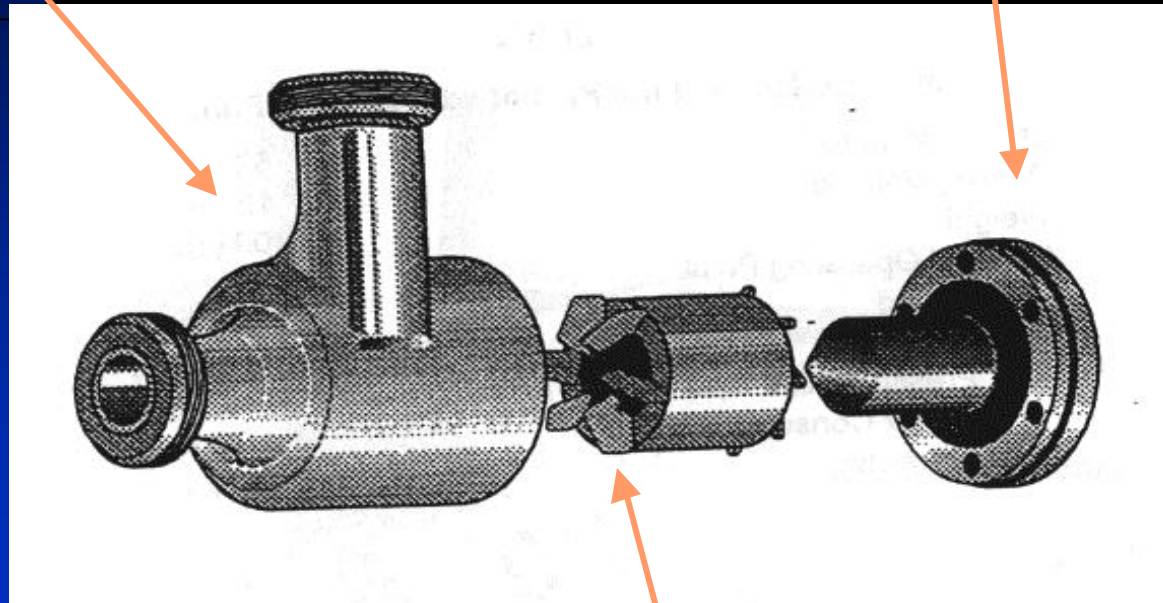

Rotor and Blades

Research Challenges

- Task I: Technology survey and overall system package Optimization

Task II: Electromagnetic optimization

Task III: Initial optimization of air bearing and compressing blades

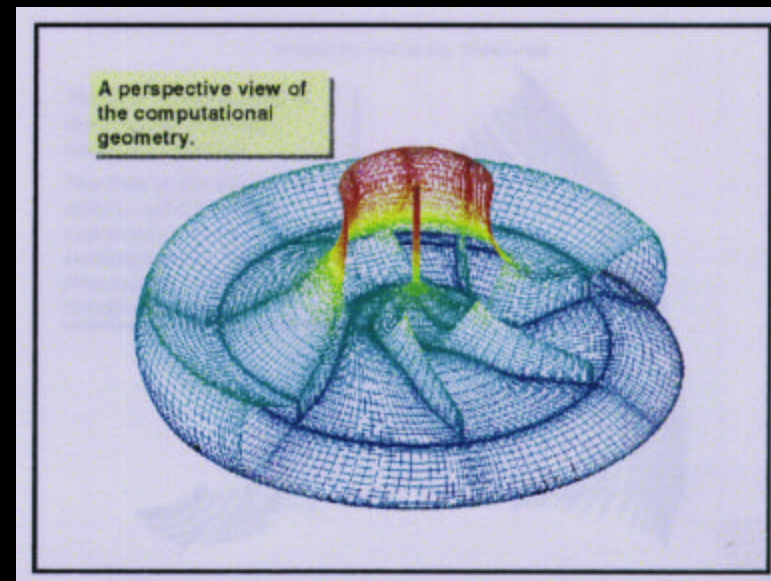
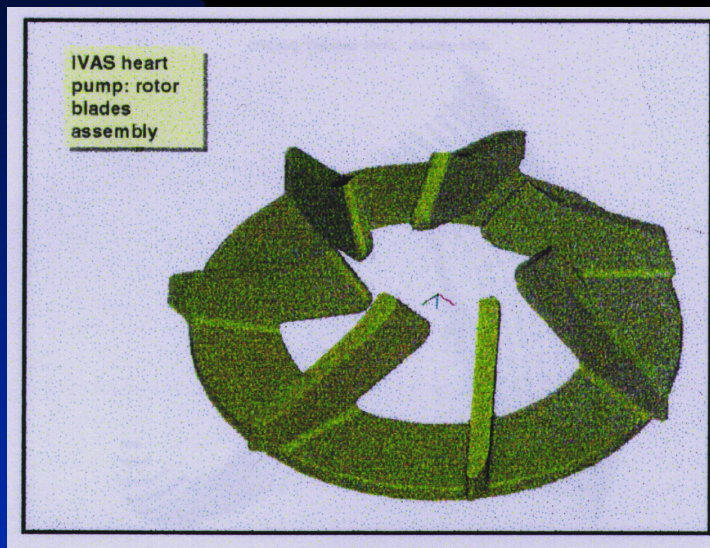

Task IV: Power Electronics and Control of Air Management System

